

**KAESER**  
COMPRESSORS®

**KERR** | Compressor  
Engineers  
Compressors • Vacuum Pumps • Blowers



# KAESER FILTER

## KF F350 to F3360 Series

Reliable purity for high flow rates

Flow rate 35.4 to 336.3 m<sup>3</sup>/min, Pressure 2 to 16 bar

[www.kerrcompressors.co.uk](http://www.kerrcompressors.co.uk)

# Clean compressed air at low cost

KAESER FILTER products are the key components for supplying compressed air of all purity classes as per the ISO 8573-1 standard – with extremely low pressure loss. Thanks to generously dimensioned nominal widths and efficient filter elements, they deliver top performance with very low pressure losses of just 0.2 bar maximum (ISO 12500-1). KAESER FILTER products are available in four filter grades. Nine models provide efficient filtration for flow rates from 35.4 to 336.3 m<sup>3</sup>/min.

## Standard-compliant purity

The KAESER FILTER range uses modern deep-pleated filter media to remove particles and aerosols. A highly effective carbon fibre mat traps oil vapours. Together with generously dimensioned nominal widths and flow cross-sections, they deliver exceptional filtration efficiency with minimal pressure loss. The outstanding performance data of KAESER FILTER products have been determined as per ISO 12500 and validated by an independent institute, IUTA e.V.

## Service-friendly design, simple handling

KAESER FILTER products feature a corrosion-resistant steel housing and a stable filter element. Threaded rods and positioning guides ensure rapid element replacement and reliable sealing of filter elements. KB and KE coalescence filters are equipped as standard with the electronic, level-actuated ECO-DRAIN 31 F Vario condensate drain. A differential pressure gauge is provided for the coalescence and particulate filter. Its design as a Bourdon tube pressure gauge delivers reliable performance for low pressure losses.

## Minimal pressure loss, maximum savings

The efficiency of a compressed air filter depends most of all on pressure loss. KAESER FILTER products feature generously sized housings and filter surfaces, as well as high-performance filter media. These features result in up to 50 % lower pressure loss compared to other filters on the market – a value that remains virtually constant throughout the entire service life of the filter element. This reduces the load on upstream compressors, thereby creating the potential for significant reductions in costs and CO<sub>2</sub> emissions.

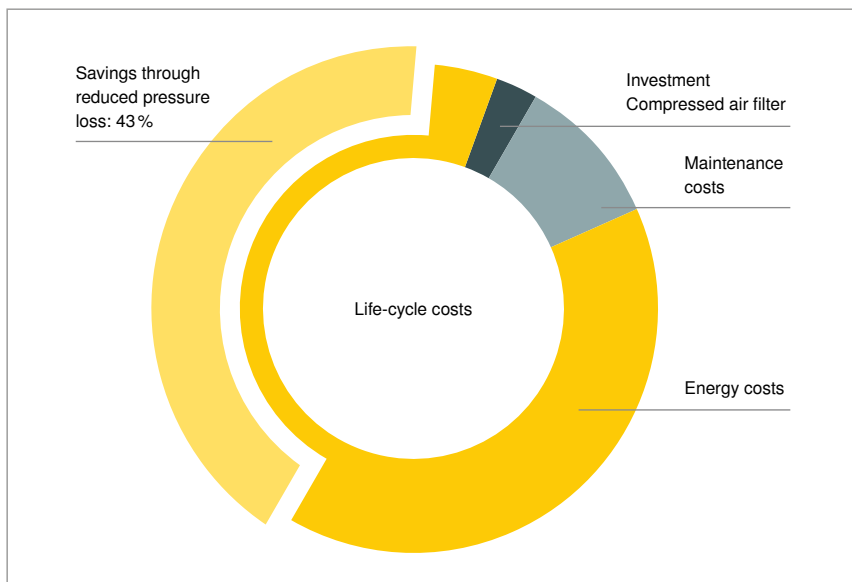

## Coalescence filter example

- Flow rate up to 88.5 m<sup>3</sup>/min
- 50 % lower pressure loss
- 6.55 kW/(m<sup>3</sup>/min)
- Additional energy requirement 6 % per bar
- Power price: 0.2 €/kWh
- 8760 operating hours p.a.
- Annual debt service over 10 years



- (01) Compressed air inlet
- (02) Connection flange, inlet
- (03) Element thread with positioning aid and flow distributor
- (04) Filter element
- (05) Connection flange, discharge
- (06) Compressed air discharge
- (07) Lifting eye
- (08) Chamber, coated and painted
- (09) Chamber cap
- (10) Ball valve tap, rotatable
- (11) ECO-DRAIN 31 F Vario
- (12) Condensate outlet
- (13) Differential pressure gauge

Image:  
 KAESER FILTER  
 F530KE - 35.40 m³/min



**Image:**  
KAESER FILTER with differential pressure gauge – implemented as a Bourdon tube pressure gauge for precise measurements in the mbar range.

# Low differential pressure for maximum efficiency

Increased energy cost per m<sup>3</sup>/min of compressed air: 6 % for 1 bar pressure drop. This rule of thumb shows that generously sized KAESER FILTER products pay off quickly, especially for high flow rates.

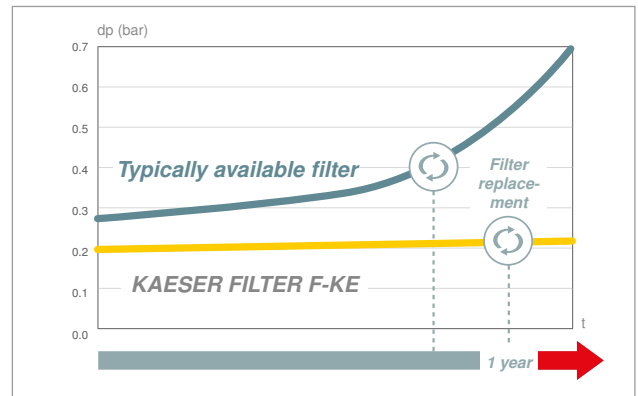
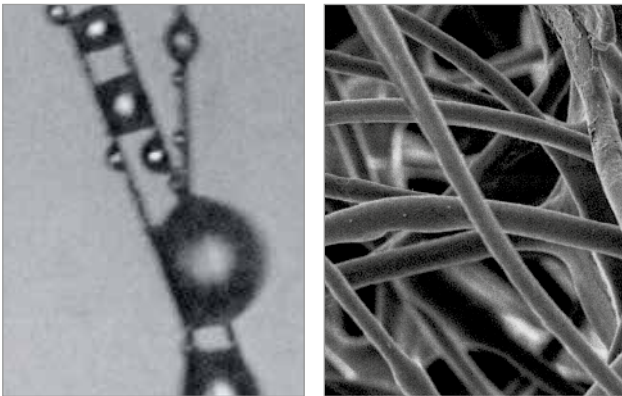

## Low flow resistance

The polyester material used in the filter drainage layer ensures rapid oil drainage (left). Moreover, to achieve optimum filtration and contaminant retention with minimal pressure loss, KAESER particulate and coalescence filters feature high void volume filter media (right).

## High particulate retention capacity

KAESER FILTER products have a far lower pressure drop right from the outset compared to other typically available filters on the market. Moreover, the pressure drop remains low for much longer thanks to the high particulate retention capacity. The result: low operating costs over the long term. The annual maintenance of particulate and coalescence filters mitigates age-related risks and ensures maximum compressed air purity.

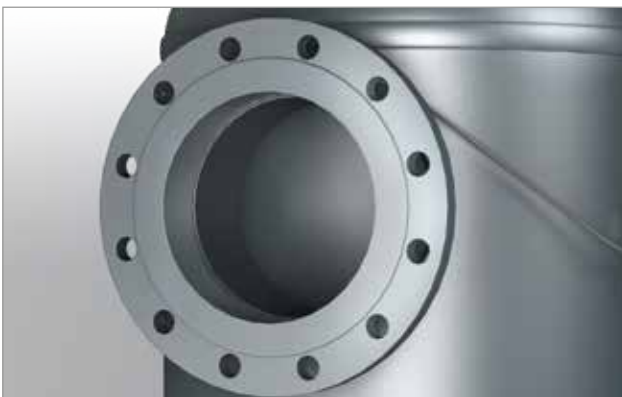

## Generously dimensioned nominal widths

KAESER FILTER products feature generously dimensioned connection flanges – often outsize typical filters on the market by a full nominal width. They integrate easily, without a reduction flange, into the line networks of modern compressed air stations, thereby avoiding unnecessary pressure loss.

## Consistently high efficiency

Fitted as standard to KAESER particulate and coalescence filters, the differential pressure gauge enables users to monitor pressure losses (i.e. efficiency) at a glance. Unlike other commonly used designs, the contaminated and clean air sides are isolated from one another.



KF F350 – F3360 series

# Standard-compliant purity in every quality class

The generously dimensioned KAESER FILTER products have proven themselves in the most sophisticated of testing environments and in stringent measurement programs. KAESER FILTER products are dependable and efficient – and are certified to prove so.

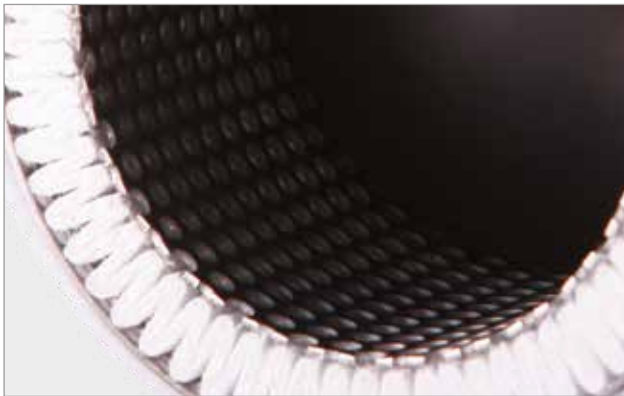

## Deep-pleated filter elements

The deep-pleated KAESER particulate and coalescence filter elements feature exceptionally large filter surfaces. Through the resulting increase in efficiency, operating costs are significantly reduced compared to conventional filter designs.

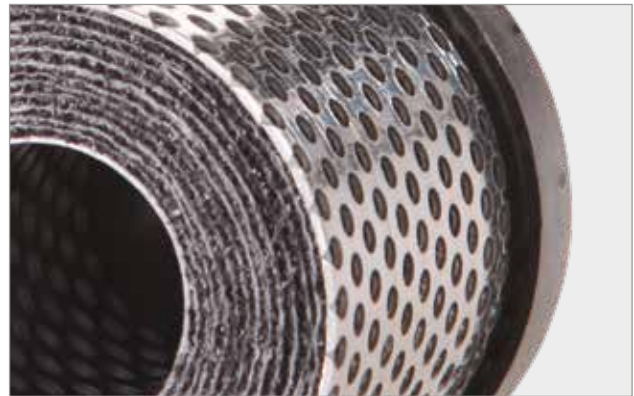

## High efficiency carbon matting

Unlike conventional filters, KAESER activated carbon filters with high-efficiency carbon matting prevent channelling and also ensure reduced differential pressure. Moreover, the matting provides highly effective protection against particulate release.



## Dependable element seating

KAESER FILTER filter elements are reliably secured inside the filter chamber with a threaded rod. When screwed in, the seal on the face of the element head presses securely against the element seating, thereby reliably preventing overflow on the clean air side.



## Certified performance specifications

The separation efficiency and pressure loss of KAESER FILTER products have been validated as per ISO 12500 standards – certified first-class performance!



Degree of filtration	KB Coalescence filter Basic	KE Coalescence filter Extra	KD Particulate filter Dust	KA Activated carbon filter Adsorption	KBE Extra Combination	KEA Carbon Combination
Initial differential pressure at saturation	< 0.15 bar	< 0.2 bar	< 0.06 bar (New, dry)	< 0.06 bar (New, dry)	< 0.2 mbar	< 0.26 bar
Aerosol content at inlet	10 mg/m <sup>3</sup>	10 mg/m <sup>3</sup>	–	–	10 mg/m <sup>3</sup>	10 mg/m <sup>3</sup>
Residual aerosol content at outlet as per ISO 12500-1:06-2007	< 0.1 mg/m <sup>3</sup>	< 0.01 mg/m <sup>3</sup>	–	–	< 0.01 mg/m <sup>3</sup>	0.003 mg/m <sup>3</sup> (Total oil content)
Filter medium	Deep-pleated with support structure and polyester drainage matting		Deep-pleated with support structure	High-efficiency carbon matting	–	–
Application	Filtration of solid and liquid aerosols and solid particulates	Same application as KB, but for higher compressed air quality Alternatively: Micro-particulate filter to KD degree of filtration	Exclusively for filtration of solid particulates	Exclusively for removal of oil vapours	Combination of KB and KE; same application as KE, but ensures higher compressed air quality	Combination of KE and KA, filtration of aerosols, solid matter particles and oil vapour

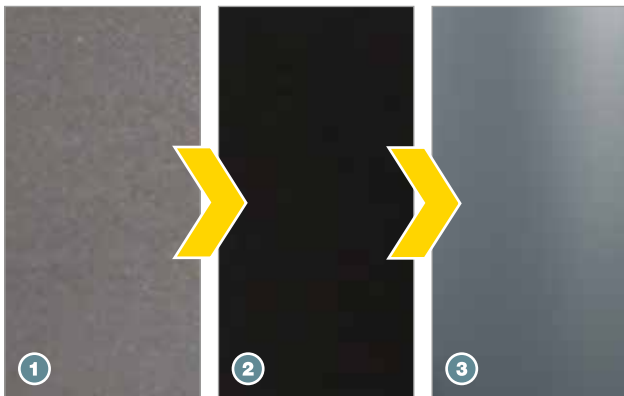

**Image:**  
KD particulate filter with manual  
condensate drain on ACT activat-  
ed carbon adsorber.



# Safe handling, service-friendly design

KAESER understands customers' needs, as the company itself operates various compressed air stations. From first hand experience, we are well-versed in all aspects of compressed air station planning, implementation, operation and maintenance. We draw on this expertise to create user-friendly and low-maintenance products.



## Corrosion-protected aluminium housing

The steel housings of KAESER FILTER products are (1) sand-blasted, (2) powder-coated and also receive a cathodic dip coating before (3) they are powder-coated. Inner and outer surfaces therefore have outstanding protection against corrosion.



## Simple positioning

Thanks to the funnel-shaped positioning guides of the filter housing, the element's threaded rods can be easily screwed on, contributing to rapid service.



## Condensate accumulation functional check

On the coalescence filters, condensate drainage can be triggered with the test button of the ECO-DRAIN 31 F VARIO fitted as standard. On particulate and activated carbon filters, a tap makes it easy to check if condensate is accumulating (= malfunction).

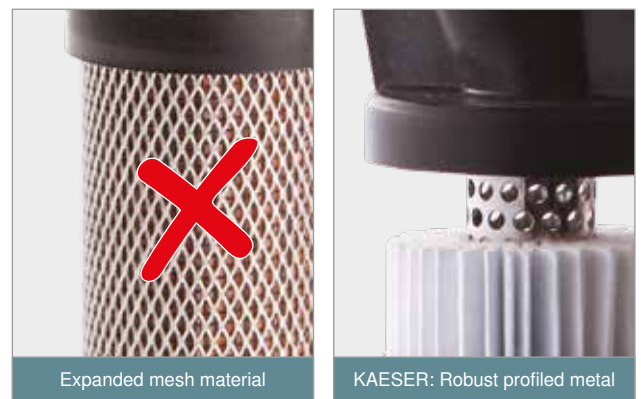

## Robust stainless steel cage

KAESER filter elements are protected by inner and outer cages made from continuously welded profiled stainless steel. These cages are far more resistant to mechanical stress than those made from simple expanded metal.

# KAESER FILTER

To ensure that the required compressed air purity level is consistently maintained, the filter elements should be replaced at the end of their service life. Dependable aerosol filtration also requires dependable condensate drainage.

The **ECO-DRAIN 31 F Vario** automatic condensate drain was especially designed for use with coalescence filters. Accumulating condensate is reliably removed without pressure loss.

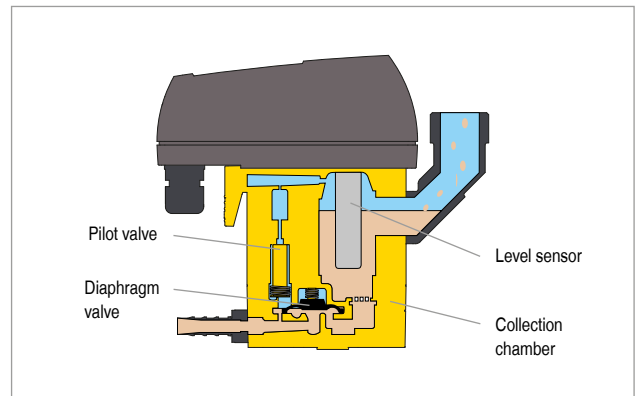
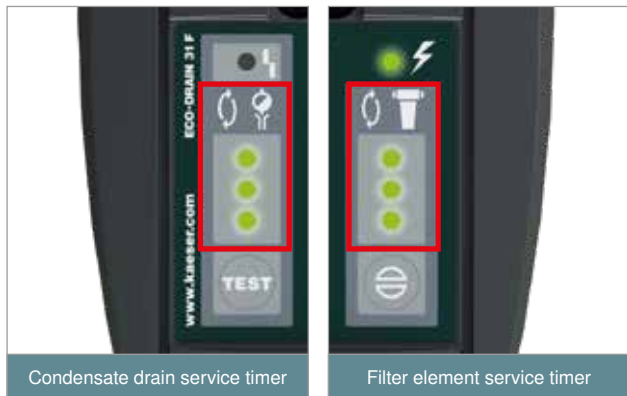

## Service life monitoring

The ECO-DRAIN 31 F Vario condensate drain not only monitors its own service interval but also that of the connected compressed air filter element. Service interval status is indicated via LEDs and a floating warning contact.

## Dependable and loss-free

With contact-free sensing, ECO-DRAIN condensate drains detect the condensate fill level and drain the condensate away via a pilot-controlled diaphragm valve without pressure loss. The large flow cross sections eliminate the need for maintenance-intensive strainers.

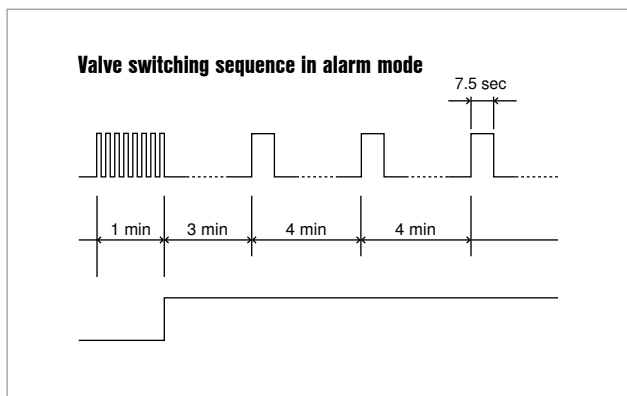

## Self-monitoring

Should an issue with condensate drainage occur, the ECO-DRAIN valve opens at short intervals for one minute. If the condensate does not drain, a message is triggered and the valve opens every 4 minutes for 7.5 seconds. Once the condensate drains, the ECO-DRAIN reverts back to normal operation.

## Checked for leaks and correct operation

All wear components of the ECO-DRAIN 31 F Vario can be swapped out by replacing the service unit – there is no need to replace the seal. To ensure trouble-free maintenance, the condensate drain and service unit are 100 % factory-tested for leaks and correct operation before they leave the plant.



Image: Coalescence filter with ECO-DRAIN 31 F Vario



Figure 1



Figure 2



Figure 3

## Equipment

### Coalescence filter

- With ECO-DRAIN 31 F Vario
- Corrosion-protected, painted steel housing with flange connection
- Differential pressure gauge and KB or KE Filter element (pre-assembled)
- Rotatable ball valve tap and ECO-DRAIN 31 F Vario electronic condensate drain with maintenance management (included)

(Figure 1)

### Particulate filter

- Corrosion-protected, painted steel housing with flange connection
- Differential pressure gauge and KD Filter element (pre-assembled)
- Manual condensate drain (included)

(Figure 2)

### Activated carbon filter

- Corrosion-protected, painted steel housing with flange connection
- KA Filter element (pre-assembled)
- Manual condensate drain (included)

(Figure 3)

# Other options



## Differential pressure transducer

Instead of the mechanical differential pressure gauge, KAESER FILTER products can optionally be equipped with a differential pressure transducer (factory-installed). The three-wire sensor transmits the differential pressure as a 4-20 mA signal. The value can then be passed on to higher-level control systems such as the SIGMA AIR MANAGER 4.0 and from there can also be transmitted to the SIGMA NETWORK.



## Silicone-free version

KAESER FILTER products also include optionally available silicone-free versions that are compliant with test standard PV-VW 3.10.7. Each filter undergoes an individual coating test to confirm compliance.

The supplied manufacturer's certificate attests that the product is silicone-free. Moreover, all filter elements for KAESER FILTER products are manufactured to be silicone-free in accordance with this regulation as standard.



# Dimensions

Model	Air connection	Volume l	B	C	D	E	F
	DN		mm	mm	mm	mm	mm
F 350	80	34	216	910	1055	1108	400
F 530	100	48	271.4	918	1099	1152	450
F 700	150	75	320	962	1180	1233	535
F 880	150	75	320	960	1180	1233	535
F 1060	150	135	401.7	960	1214	1267	600
F 1410	200	220	503.6	993	1299	1352	720
F 1940	200	220	503.6	993	1299	1352	720
F 2470	250	250	550	1024	1387	1440	750
F 3360	250	350	602.5	1066	1429	1482	850

Compressed air connection: PN16 as per DIN EN 1092-1

# Views

Models shown: F3360

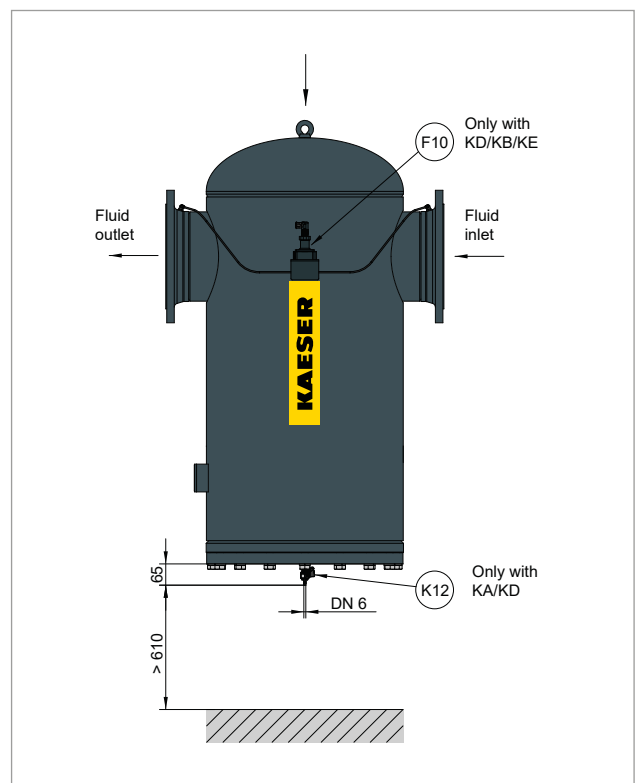
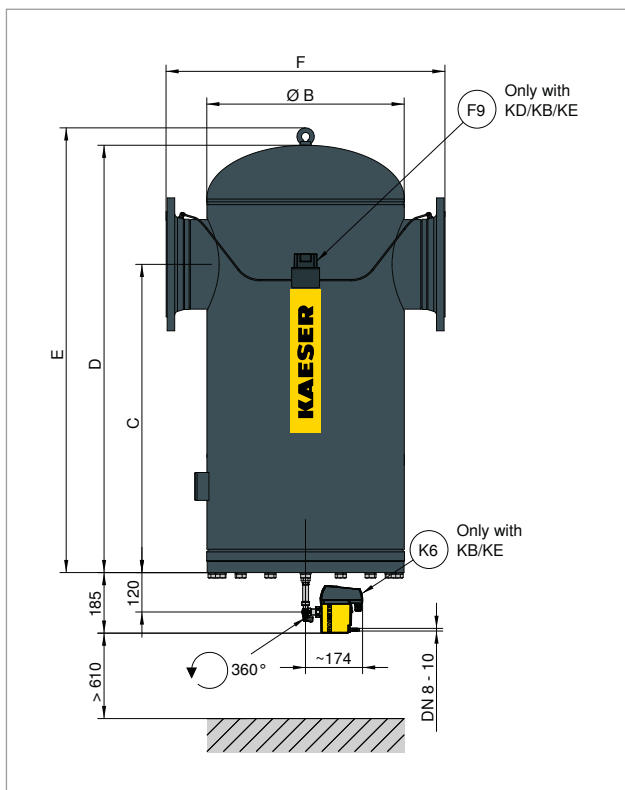

# Technical specifications

Model	Flow rate * m³/min	Gauge pressure bar	Ambient temperature °C	Compressed air inlet temperature °C	Maximum mass kg	Electrical supply ECO-DRAIN
F 350	35.40	2 to 16	+3 to +50	+3 to +66	54	95...240 VAC ± 10 % (50...60 Hz) / 100...125 VDC ± 10 %
F 530	53.10	2 to 16	+3 to +50	+3 to +66	76	
F 700	70.80	2 to 16	+3 to +50	+3 to +66	107	
F 880	88.50	2 to 16	+3 to +50	+3 to +66	107	
F 1060	106.20	2 to 16	+3 to +50	+3 to +66	162	
F 1410	141.60	2 to 16	+3 to +50	+3 to +66	262	
F 1940	194.70	2 to 16	+3 to +50	+3 to +66	270	
F 2470	247.80	2 to 16	+3 to +50	+3 to +66	287	
F 3360	336.30	2 to 16	+3 to +50	+3 to +66	340	

\* Performance data at 7 bar gauge pressure based on 1 bar ambient pressure absolute and 20 °C. The flow rate differs for deviating operating conditions.

## Calculating flow rate

Correction factors for deviating operating conditions (flow rates in m³/min x k...)

Deviating working pressure p at filter inlet															
p bar <sub>(g)</sub>	2	3	4	5	6	7	8	9	10	11	12	13	14	15	16
k <sub>p</sub>	0.38	0.50	0.63	0.75	0.88	1.00	1.06	1.12	1.17	1.22	1.27	1.32	1.37	1.41	1.46

Example:				
Working pressure	8 bar	->	Factor	1.06

KAESER FILTER F 880 with flow rate of 88.50 m³/min
Max. possible flow rate under operating conditions
$V_{\text{max Operation}} = V_{\text{Reference}} \times k_p$
$V_{\text{max Operation}} = 88.50 \text{ m}^3/\text{min} \times 1.06 = 93.81 \text{ m}^3/\text{min}$



# The world is our home

As one of the world's largest compressed air system providers and compressor manufacturers, KAESER KOMPRESSOREN is represented throughout the world by a comprehensive network of branches, subsidiary companies and authorised partners in over 140 countries.

With innovative products and services, KAESER KOMPRESSOREN's experienced consultants and engineers help customers to enhance their competitive edge by working in close partnership to develop progressive system concepts that continuously push the boundaries of performance and compressed air efficiency.

Moreover, the decades of knowledge and expertise from this industry-leading system provider are made available to each and every customer via the KAESER group's global computer network.

These advantages, coupled with KAESER's worldwide service organisation, ensure that every product operates at the peak of its performance at all times and provides maximum availability.



**KERR** | Compressor  
Engineers  
Compressors • Vacuum Pumps • Blowers

## Kerr Compressor Engineers (EK) Ltd

37 Fairfield Place, College Milton, East Kilbride, **Glasgow** G74 5LP

Tel: 01355 248 222 • [web.enquiry@kerrcompressors.co.uk](mailto:web.enquiry@kerrcompressors.co.uk)

[www.kerrcompressors.co.uk](http://www.kerrcompressors.co.uk)

Follow us on [LinkedIn](#)